

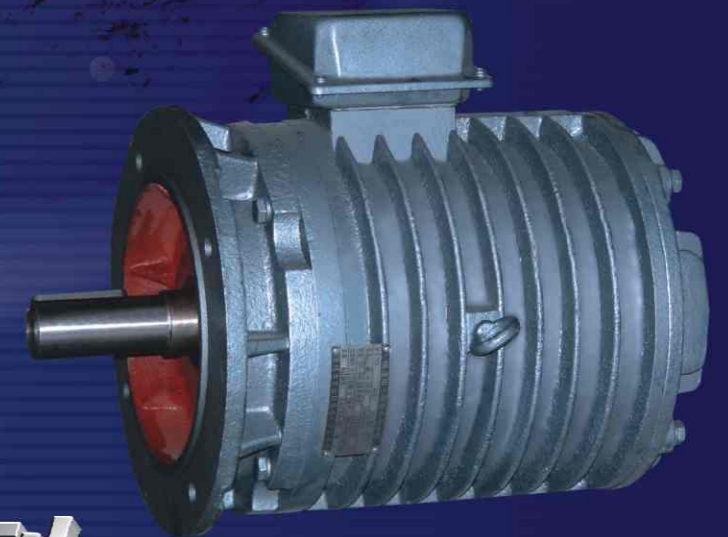

精工卓越 开拓创新



无锡宏泰



YGP系列

辊道用变频调速三相异步电动机

无锡市宏泰起重电机有限公司
(原无锡市宏达起重电机厂)

地址: 江苏省无锡市惠山区前洲镇水月浜路2号
电话: 0510-83390388 83391074
传真: 0510-83390288
总经理室: 0510-83392288
传真: 0510-83395888
邮编: 214181
<http://www.hongtaimotor.com>



承载科技光芒 触发卓越动力

企业简介

BRIEF INTRODUCTION OF CORPORATION

企业荣誉

GLORY OF CORPORATION

企业宗旨：

为顾客创造价值，为员工创造机遇，为社会创造效益。

企业精神：

敬业、团队、创新

经营理念：

诚信务实、以客为先

竞争策略：

研制最好的产品，提供最好的服务，创建最好的品牌。

无锡市宏泰起重电机有限公司（原无锡市宏达起重电机厂）始建于1958年，于1998年改制。是国内较早从事起重和冶金电动机的生产专业厂家，是中国重机协会、上海电机行业协会会员企业。企业先后荣获国家水利部部级先进企业、无锡市明星企业、AAA级企业、重合同守信用企业等一系列荣誉称号。

本公司主要产品为YZR、YZ、YZRE、YZE、JZR2系列起重冶金用电动机、YZP、YZB、YZPE、YZBE系列起重及冶金用变频调速及变频调速电磁制动电动机、YG、YGP系列辊道及辊道变频调速电动机，YP、YP2、YPE、YP2E系列变频调速及变频调速电磁制动电动机，YZRW、WZ系列涡流制动电动机及涡流制动器，YR、JR绕线转子矿用电动机，另外还专业生产ZDY系列锥形转子电动机、YZU系列振动源电动机、YTS系列脱水机电动机、Y系列三相异步电动机及KZ、F1、F2、D1、D2、Z4直流电动机等共计35个系列，450个品种，年生产电机能力达58万千瓦。在起重变频电机YZP（F）、YZB（F）的设计上，参照国外先进技术，全部采用冷轧矽钢片，出线盒在电机顶部，和变频器匹配性能优异，并可根据用户要求选配编码器、超速开关、热敏电阻，在行业中具有一定的领先性。

本公司占地面积38000平方米，建筑面积29800平方米。1999年、2001年荣获江苏质量技术监督局颁发的监督检查合格证书，2004年6月取得国家起重冶金电机质量监督检验中心YZR112~400起重冶金用绕线转子三相异步电动机型式试验合格证书。并已通过ISO9001：2000版的换版认证。在质量上，坚持精雕细琢造精品；在服务上，提倡卓越服务百分百。在国内港口、起重、冶金、建筑等行业具有良好的声誉及一定的市场占有率，部分产品出口美国、日本、朝鲜、东南亚等国家和地区。

我们将以先进的技术、严谨的管理、高质量的产品、完善的服务奉献给各方朋友。



YGP系列 辊道用变频调速三相异步电动机

概述:

YGP系列辊道用变频调速三相异步电动机是以变频调速装置为供电电源而达到无级调速的电动机，其在YG系列辊道用三相异步电动机的基础上改进设计后，具有过载能力强，调速范围广，精度好，运行稳定等特点。适用于驱动冶金工业的传送辊道等要求连续调速和频繁起、制动及正、反转的各种辊道设备。

该产品可与国内外各种变频装置配套使用。

电动机可附装：热保护器、加热器、编码器、电磁制动器等附加装置，以满足用户需求。

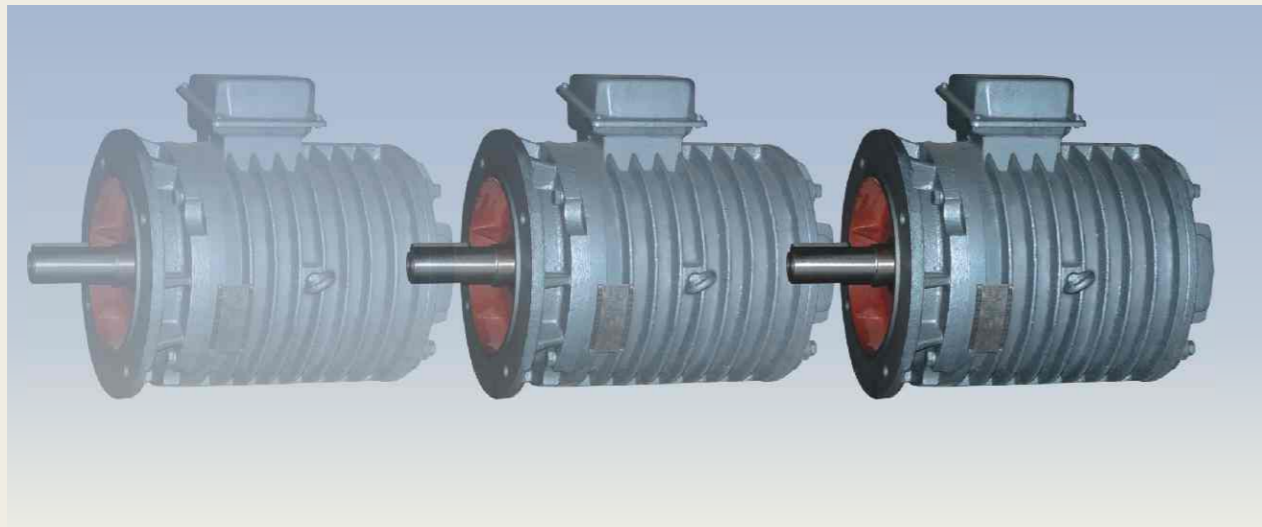

型号说明

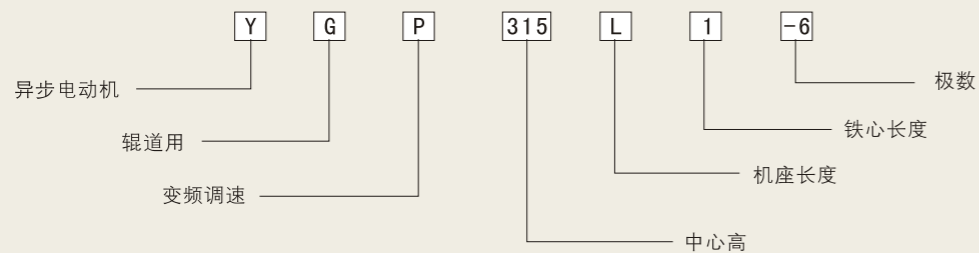

使用条件及其性能

- 适应变频器输出的高载波频率电压
- 额定电压380V，额定频率50Hz（要求其它频率或频率范围可在定货时提出）
- 绝缘等级H级，防护等级IP54和IP55
- 可在S1-S9工作下运行，数据表中功率为S1连续工作制下的功率设计值（见表1），仅供用户选型时参考
- 调速范围1Hz-100Hz；1-50Hz为恒转矩调速；50-100Hz为恒功率调速
- 冷却方式IC410（表面自然冷却）

技术数据 Technical Data Table

表1

型号 TYPE	标称功率 (KW) NORMAL POWER	额定电流 (A) RATED CURRENT	额定转矩 (N.M) RATED TORQUE	转速 SPEED (r/min)	堵转转矩 额定转矩 (倍)	最大转矩 额定转矩 (倍)	转动惯量 (Kg.m ²) MONENT OF INERTIA	重量 WEIGHT (kg)
					LOCK TORQUE	MAX TORQUE		
					RATED TORQUE	RATED TORQUE		
YGP112L1-4	1.1	2.5	7.3	1450	1.5-2.2 (1Hz)	4.0 (50Hz)	0.0112	57
YGP112L2-4	1.5	3	10	1450			0.0166	66
YGP132M1-4	2.2	4.5	14.5	1450			0.0251	90
YGP132M2-4	3	6	20	1450			0.0333	98
YGP132L-4	3.7	7.8	24.1	1465			0.0412	102
YGP160S1-4	4	8	26.2	1460			0.0646	131
YGP160S2-4	5.5	11	36	1460			0.0841	142
YGP160L1-4	7.5	14.5	49.1	1460			0.114	172
YGP160L2-4	9	17	59	1465			0.139	190
YGP180L1-4	11	20.5	71.7	1465			0.158	229
YGP180L2-4	15	28	97.8	1470			0.175	252
YGP200L1-4	18.5	33.5	120	1470			0.263	302
YGP200L2-4	22	40	142.7	1475			0.3	337
YGP225M1-4	25	44.5	162	1475			0.469	410
YGP225M2-4	30	54.5	194	1475			0.495	445
YGP250M-4	37	65.5	239	1480			0.66	500
YGP280L1-4	45	79	290	1485			1.46	700
YGP280L2-4	55	96	355	1485			1.825	800
YGP280L3-4	75	129	484	1485			2.19	1000
YGP315M-4	80	149	513	1485			3.62	1110
YGP315L1-4	90	154	579	1490	4.13	1135		
YGP315L2-4	110	188	708	1490	4.94	1165		

YGP系列 辊道用变频调速三相异步电动机

续表1

型号 TYPE	标称功率 (KW) NORMAL POWER	额定电流 (A) RATED CURRENT	额定转矩 (N.M) RATED TORQUE	转速 SPEED (r/min)	堵转转矩	最大转矩	转动惯量 (Kg.m ²) MONENT OF INERTIA	重量 WEIGHT (kg)
					额定转矩 (倍)	额定转矩 (倍)		
					LOCK TORQUE RATED TORQUE	MAX TORQUE RATED TORQUE		
YGP355M1-4	132	224	846	1490	1.5-2.2 (1Hz)	4.0 (50Hz)	7.53	1200
YGP355M2-4	160	275	1025	1490			7.72	1500
YGP400L1-4	200	350	1279	1494			11.0	2000
YGP400L2-4	250	440	1604	1494			13.5	2300
YGP112L1-6	0.75	2.0	7.4	965	1.5-2.0 (1Hz)	3.8 (50Hz)	0.0112	57
YGP112L2-6	1.1	2.7	11	965			0.0166	66
YGP132M1-6	1.5	3.4	15	965			0.0251	90
YGP132M2-6	2.2	4.8	22	965			0.0333	98
YGP132L-6	2.8	7.0	27.4	975			0.0448	108
YGP160S1-6	3	7.2	29.5	970			0.0646	131
YGP160S2-6	4	8.5	39.4	970			0.0841	142
YGP160L1-6	5.5	11.5	54	970			0.114	172
YGP160L2-6	7.5	15	73.5	975			0.139	190
YGP180L1-6	9	17.5	88.1	975			0.158	229
YGP180L2-6	11	21.5	107.8	975			0.175	252
YGP200L1-6	15	28.5	147	975			0.263	302
YGP200L2-6	18.5	34	181	975			0.3	337
YGP225M1-6	22	40	215	975			0.469	410
YGP225M2-6	25	46	245	975			0.495	445
YGP250M-6	30	54.5	292	980			0.66	500
YGP280L1-6	37	67	359	985			1.46	700
YGP280L2-6	45	81	436	980			1.825	800
YGP280L3-6	55	97	533	985			2.19	1000
YGP315M-6	63	120	607	990			4.78	1110
YGP315L1-6	75	134	724	990	5.45	1135		
YGP315L2-6	90	162	868	990	6.12	1165		
YGP355M1-6	110	197	1061	990	7.53	1200		
YGP355M2-6	132	235	1273	990	7.72	1500		
YGP355L-6	150	280	1453	985	10.5	1850		
YGP400L1-6	160	290	1537	990	11.0	2000		
YGP400L2-6	200	360	1922	990	13.5	2300		

续表1

型号 TYPE	标称功率 (KW) NORMAL POWER	额定电流 (A) RATED CURRENT	额定转矩 (N.M) RATED TORQUE	转速 SPEED (r/min)	堵转转矩	最大转矩	转动惯量 (Kg.m ²) MONENT OF INERTIA	重量 WEIGHT (kg)
					额定转矩 (倍)	额定转矩 (倍)		
					LOCK TORQUE RATED TORQUE	MAX TORQUE RATED TORQUE		
YGP112L1-8	0.55	1.6	7.3	725	1.5-2.0 (1Hz)	3.8 (50Hz)	0.0112	57
YGP112L2-8	0.75	2	10	725			0.0166	66
YGP132M1-8	1.1	3.2	14.5	725			0.0251	90
YGP132M2-8	1.5	4.3	20	725			0.0333	98
YGP132L-8	1.8	5.0	23.8	725			0.0448	108
YGP160S1-8	2.2	5.5	30	725			0.0646	131
YGP160S2-8	3	7	39.5	725			0.0841	142
YGP160L1-8	4	9.5	52.7	725			0.114	172
YGP160L2-8	5.5	13	72.5	725			0.139	190
YGP180L1-8	7.5	17	98	730			0.237	229
YGP180L2-8	9	20	117.7	730			0.294	252
YGP200L1-8	11	25	143	735			0.36	302
YGP200L2-8	15	30	185	735			0.509	337
YGP225M1-8	18.5	38	240	735			0.547	410
YGP225M2-8	22	45	286	735			0.623	445
YGP250M-8	25	49	325	735			0.834	500
YGP280L1-8	30	60	390	735			1.65	700
YGP280L2-8	37	72	481	735			2.06	800
YGP280L3-8	45	87	585	735			2.48	1000
YGP315M-8	50	105	641	740			5.58	1110
YGP315L1-8	55	108	710	740	6.37	1135		
YGP315L2-8	75	142	968	740	7.23	1165		
YGP355M1-8	90	168	1161	740	9	1300		
YGP355M2-8	110	210	1419	740	11	1500		
YGP355L-8	125	249	1610	740	13.8	1850		
YGP400L1-8	132	260	1692	745	18.8	2000		
YGP400L2-8	160	320	2051	745	23	2300		
YGP132M1-10	0.75	2.5	12.4	580	1.5-2.0 (1Hz)	3.8 (50Hz)	0.0251	90
YGP132M2-10	1.1	4	18	580			0.0333	98
YGP160S1-10	1.5	5	24.6	580			0.0646	131
YGP160S2-10	2.2	7.2	36	580			0.0841	142

YGP系列 辊道用变频调速三相异步电动机

续表1

型号 TYPE	标称功率 (KW) NORMAL POWER	额定电流 (A) RATED CURRENT	额定转矩 (N.M) RATED TORQUE	转速 SPEED (r/min)	堵转转矩	最大转矩	转动惯量 (Kg.m ²) MONENT OF INERTIA	重量 WEIGHT (kg)
					额定转矩 (倍) LOCK TORQUE	额定转矩 (倍) MAX TOROUE		
					RATED TORQUE	RATED TOROUE		
YGP160L1-10	3	9.8	49.2	580	1.5-2.0 (1Hz)	3.8 (50Hz)	0.114	172
YGP160L2-10	4	12	66	580			0.139	190
YGP180L1-10	5.5	14	90	585			0.237	229
YGP180L2-10	7.5	19	122.4	585			0.294	252
YGP200L1-10	9	23	147	585			0.36	302
YGP200L2-10	11	26	176	585			0.509	337
YGP225M1-10	15	34	245	585			0.547	410
YGP225M2-10	18.5	41	602	585			0.623	445
YGP250M-10	22	48	359	585			0.834	500
YGP280L1-10	25	54	405	590			1.65	700
YGP280L2-10	30	67	486	590			2.06	800
YGP280L3-10	37	77	599	590			2.48	1000
YGP315M-10	40	90	645	590			5.15	1030
YGP315L1-10	45	92	728	590			5.45	1098
YGP315L2-10	55	114	890	590			6.12	1165
YGP355M1-10	75	165	1204	595			9	1300
YGP355M2-10	90	185	1445	595			11	1500
YGP400L1-10	110	215	1767	595			18.8	2000
YGP400L2-10	132	265	2120	595			23	2300
YGP132M1-12	0.55	2.5	10.8	485			1.5-2.0 (1Hz)	3.6 (50Hz)
YGP132M2-12	0.75	3.5	14.8	485	0.0333	98		
YGP160S1-12	1.1	5	21.7	485	0.0646	131		
YGP160S2-12	1.5	6.3	29.5	485	0.0841	142		
YGP160L1-12	2.2	8.8	43.3	485	0.114	172		
YGP160L2-12	3	12	59	485	0.139	190		
YGP180L1-12	4	13.5	79	485	0.237	229		
YGP180L2-12	5.5	17	108.5	485	0.294	252		
YGP200L1-12	7.5	23	148	485	0.36	302		
YGP200L2-12	9	25	177	485	0.509	337		
YGP225M1-12	11	30	217	485	0.547	410		
YGP225M2-12	15	42	295	485	0.623	445		

续表1

型号 TYPE	标称功率 (KW) NORMAL POWER	额定电流 (A) RATED CURRENT	额定转矩 (N.M) RATED TORQUE	转速 SPEED (r/min)	堵转转矩	最大转矩	转动惯量 (Kg.m ²) MONENT OF INERTIA	重量 WEIGHT (kg)		
					额定转矩 (倍) LOCK TORQUE	额定转矩 (倍) MAX TOROUE				
					RATED TORQUE	RATED TOROUE				
YGP250M-12	18.5	47.5	361	490	1.5-2.0 (1Hz)	3.6 (50Hz)	0.834	500		
YGP280L1-12	22	54	429	490			1.65	700		
YGP280L2-12	25	62	487	490			2.06	800		
YGP280L3-12	30	70	585	490			2.48	1000		
YGP315L1-12	37	88	721	490			5.45	1098		
YGP315L2-12	45	105	877	490			6.12	1165		
YGP355M1-12	55	130	1062	495			9	1300		
YGP355M2-12	75	175	1448	495			11	1500		
YGP400L1-12	90	185	1738	495			18.8	2000		
YGP400L2-12	110	220	2124	495			23	2300		
YGP160S1-16	0.75	4.5	19.9	360			1.5-2.0 (1Hz)	3.0 (50Hz)	0.0646	131
YGP160S2-16	1.1	6.5	29.2	360					0.0841	142
YGP160L1-16	1.5	9	39.7	360					0.114	172
YGP160L2-16	2.2	12	54.2	360					0.139	190
YGP180L1-16	3	16	78.5	365	0.237	229				
YGP180L2-16	4	20	105	365	0.294	252				
YGP200L1-16	5.5	26	144	365	0.36	302				
YGP200L2-16	7.5	31	196	365	0.509	337				
YGP225M1-16	9	36	236	365	0.547	410				
YGP225M2-16	11	42	288	365	0.623	445				
YGP250M-16	15	48	393	365	0.834	500				
YGP280L1-16	18.5	60	484	365	1.65	700				
YGP280L2-16	22	68	576	365	2.06	800				
YGP280L3-16	25	80	654	365	2.48	1000				
YGP315L1-16	30	99	785	365	5.45	1098				
YGP315L2-16	37	120	968	365	6.12	1165				
YGP355M1-16	45	130	1162	370	9	1300				
YGP355M2-16	55	165	1420	370	11	1500				
YGP400L1-16	75	190	1936	370	18.8	2000				
YGP400L2-16	90	210	2323	370	23	2300				

YGP系列 辊道用变频调速三相异步电动机

外形及安装尺寸

常用安装型式与适用的机座号的外形及安装尺寸，B3（机座无底脚，端盖无凸缘）见表2。B35（机座带底脚，端盖有凸缘）见表3。B5（机座无底脚，端盖有凸缘）见表4。其它安装型式可在定货时提出。

电动机的接线盒标准位置，从轴伸端视之，YGP112-225在机座左侧，YGP250-400在机座顶部（其它位置要求可在定货时提出）。

电动机的标准轴伸为直轴伸，如需要锥形轴伸（尺寸见表5）或双轴伸（尺寸协议商定）须在定货时提出。电动机总长尺寸在安装附件后有加长变化。

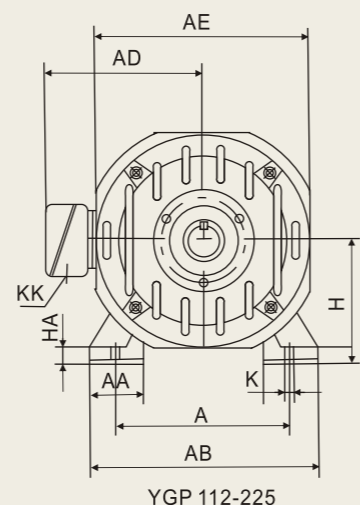

B3型外形及安装尺寸



表2

机座号	安装尺寸											外形尺寸								
	A	B	C	D	E	F	G	GD	H	K	KK	AA	AB	AD	AE	BB	B1	HA	HD	L
YGP112L	190	159	70	32K6	80	10	27	8	112	12	M36 x 2	57	235	205	240	200	20	18	235	445
YGP132M	216	178	89	38K6			33					132	220	265	265	220	20	22	270	500
YGP132L		203 (250)		340	608															
YGP160S	254	178	108	48K6	110	14	42.5	9	160	15		243	565							
YGP160L		254		316			685													
YGP180L	279	279	121	55m6	140	16	49	10	180	19	M48 x 2	85	360	290	365	325	23	25	365	730
YGP200L	318	305	133	65m6			18				58	11	200	90	415	320	420	365	30	25
YGP225M	356	311	149	75m6	140	20	67.5	12	225	24	2-M52 x 2	115	465	345	470	395	50	35	465	840
YGP250M	406	349	168				250		500			72	40	620	850					
YGP280L	457	457 (500)	190	80m6	170	22	71	14	280	28	2-M52 x 2	130	565	-	560	740	82	45	720	1100
YGP315M	508	457	216	90m6			25		81			315	660	80	45	790	1200			
YGP315L		508 (560)		660 (700)	79 (77)	1200 (1240)														
YGP355M	610	560	254	100m6	210	28	90 (100)	16	355	28	2-M58 x 2	120	720	-	740	810	91	55	860	1370
YGP355L		630					1370													
YGP400L	686	710	280	130m6	250	32	119	18	400	35	-	140	830	-	828	850	67	60	960	1540

注：括号为非标准尺寸，需要时定货提出。

YGP系列 辊道用变频调速三相异步电动机

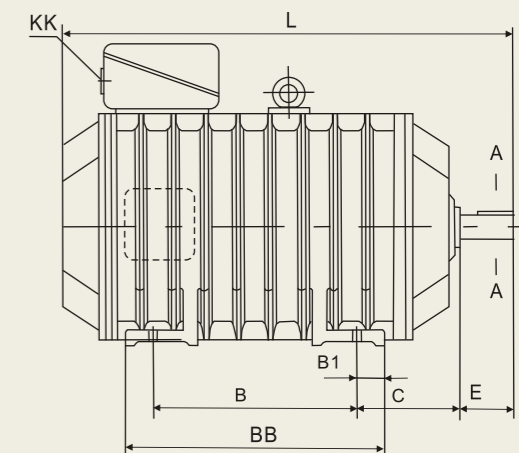
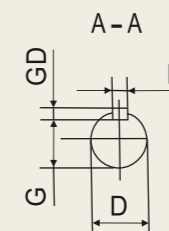
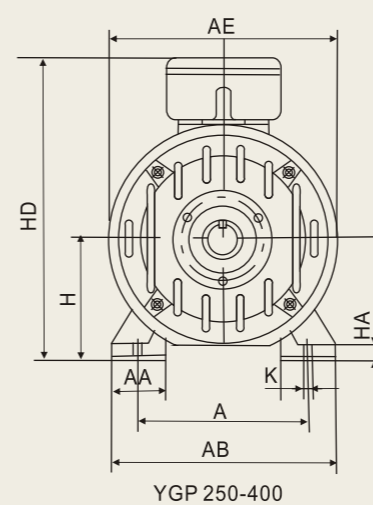
B35型外形及安装尺寸



表3

机座号	安装尺寸																	外形尺寸																					
	A	B	C	D	E	F	G	GD	H	K	KK	M	N	P	R	S	T	AA	AB	AD	AE	BB	B1	HA	HD	LA	L												
YGP112L	190	159	70	32K6	80	10	27	8	112	12	M36 x 2	215	180j6	250	0	15	4	57	235	205	240	200	20	18	235	15	445												
YGP132M	216	178	89	38K6														14	42.5	9	160	15	300	265	230j6		300	19	5	65	265	220	265	220	20	22	270	500	
YGP132L		203 (250)		48K6																										110	16	49	10	180	19	5	70	315	245
YGP160S	254	178	108	48K6	14	42.5	9	160	15	300	250j6	350	19	5	0	19	5	70	315	245	315	243	28	25	320	565													
YGP160L		254																48K6	110	16	49	10	180	19	5	85	360	290	365	325	23	25	365	685					
YGP180L	279	279	121	55m6	140	18	58	11	200	19	M48 x 2	400	350j6	450	0	19	5	85	360	290	365	325	23	25	365	18	730												
YGP200L	318	305	133	65m6														20	67.5	12	225	24	550	500	450j6	550	0	19	5	90	415	320	420	365	30	25	415	20	780
YGP225M	356	311	149	75m6														20	67.5	12	225	24	550	500	450j6	550	0	19	5	115	465	345	470	395	50	35	465	22	840
YGP250M	406	349	168	75m6	170	22	71	14	280	24	2-M52 x 2	600	550j6	660	0	24	6	115	480	-	490	500	72	40	620	24	850												
YGP280L	457	457 (500)	190	80m6														22	71	14	280	24	550	500	450j6		550	0	24	6	130	565	-	560	740	82	45	720	1100
YGP315M	508	457	216	90m6														25	81	14	315	28	660	600	550j6		660	0	24	6	120	630	-	635	660	80	45	790	26
YGP315L		508 (560)			90m6	170	25	81	14	315	28	660	600	550j6	660	0	24									6					-	-	-	635	660 (700)	79 (77)	45	790	26
YGP355M	610	560	254	100m6	210	28	90 (100)	16	355	28	2-M58 x 2	740	680j6	800	0	24	6	120	720	-	740	810	91	55	860	28	1370												
YGP355L		630																100m6	210	28	90 (100)	16	355	28	800		740	680j6	800	0	24	6	-	-	-	740	810	91	55
YGP400L	686	710	280	130m6	250	32	119	18	400	35	2-M58 x 2	740	680j6	800	0	24	6	140	830	-	828	850	67	60	960	28	1540												

注：括号为非标准尺寸，需要时定货提出。

YGP系列 辊道用变频调速三相异步电动机

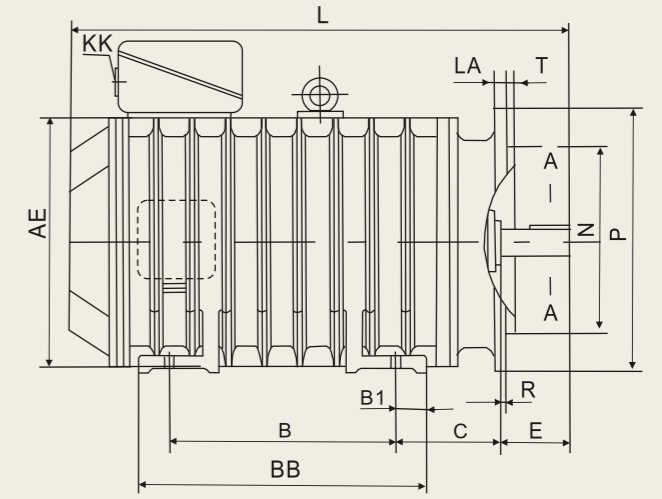
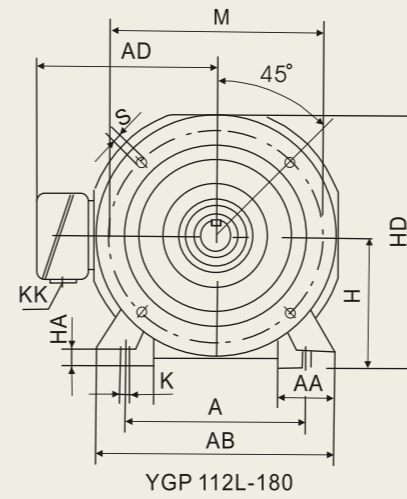
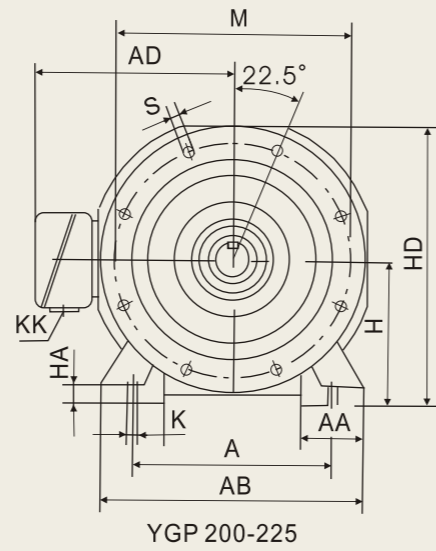
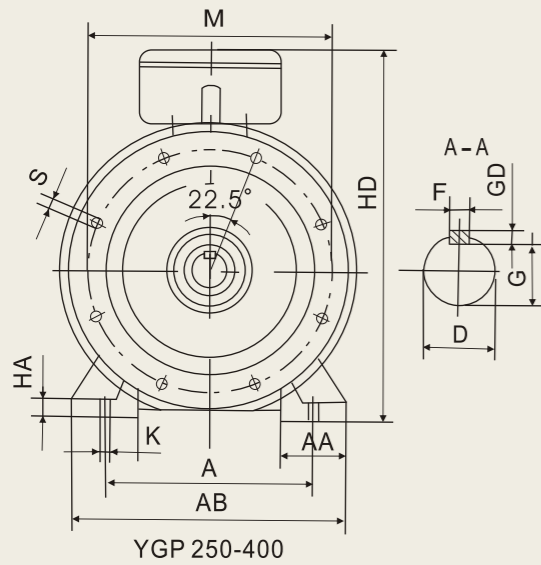
B5型外形及安装尺寸

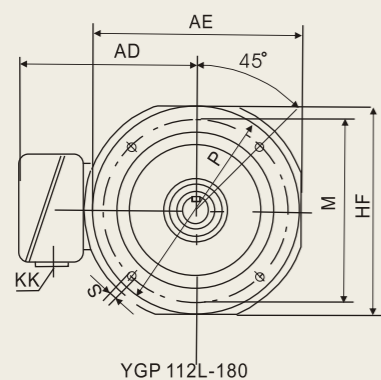

YGP 112L-180

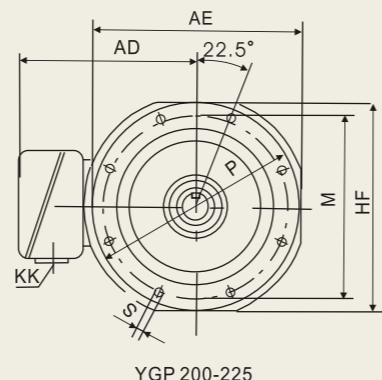

YGP 200-225



表4

机座号	安装尺寸											外形尺寸					
	D	E	F	G	GD	M	N	P	R	S	T	KK	AE	AD	HF	L	LA
YGP112L	32K6 ^(+0.018/+0.002)	80	10	27	8	215	180js6 ^(+0.013/-0.013)	250	0	15	4.0	M36 x 2	240	205	235	445	15
YGP132M	38K6 ^(+0.018/+0.002)					265	230js6 ^(+0.015/-0.015)	300					500				
YGP132L						33	600										
YGP160S	48K6 ^(+0.018/+0.002)	110	14	42.5	9	300	250js6 ^(+0.015/-0.015)	350	19	5.0	M48 x 2	315	245	335	565	685	
YGP160L												365	290	360	730	18	
YGP180L	55M6 ^(+0.030/+0.011)	140	18	58	11	400	350js6 ^(+0.018/-0.018)	450	19	5.0	M48 x 2	420	320	455	780	20	
YGP200L	470											345	460	840	22		
YGP225M	75M6 ^(+0.030/+0.011)											20	67.5	12			

锥形轴伸尺寸

表5

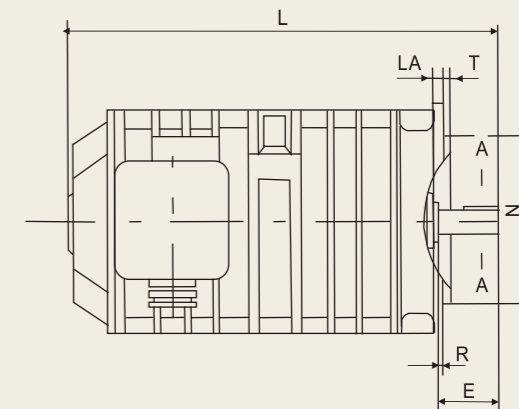
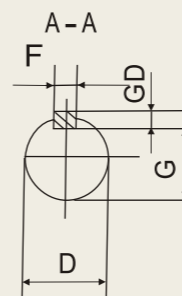
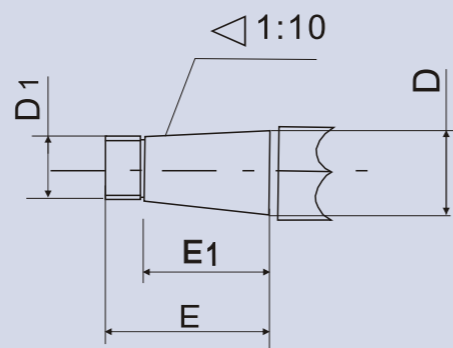
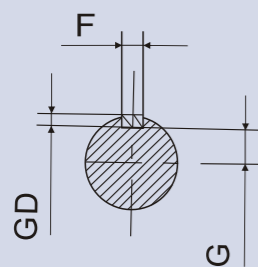

型号	代号	D	D1	E	E1	F	G	GD
YGP180		55	M36 x 3	110	82	14	19.9	9
YGP200		65	M42 x 3	140	105	16	23.9	10
YGP225		70	M48 x 3	140	105	18	25.4	11
YGP250		70	M48 x 3	140	105	18	25.4	11
YGP280		85	M56 x 3	170	130	20	31.7	12
YGP315		95	M64 x 3	170	130	22	35.2	14
YGP355		110	M80 x 3	210	165	25	41.9	14
YGP400		130	M100 x 3	250	200	28	50	16